

BLV-TPFLM-80-25-4.2(BLV-BFD-10/35-L-A)型平衡阀 BLV-TPFLM-80-25-4.2(BLV-BFD-10/35-L-A) Type Counterbalance Valve

型号说明 Model Code

BLV - TPFLM - 80 - 25 - 4.2
1 2 3 4 5 6

- 1.公司名称：BLV-博尔法；
- 2.系列型号：TPF-单向可调平衡阀、STPF-双向可调平衡阀；
- 3.连接形式：LM-螺纹连接、BM-板式连接+螺纹连接；
- 4.额定流量：40-40L/min、60-60L/min、80-80L/min、100-100L/min；
- 5.额定压力：25-25MPa、35-35MPa；
- 6.开启比：4.2-4.2:1、4.5-4.5:1、5.2-5.2:1、8.2-8.2:1、10-10:1；

1. Company Name : BLV- BOLEV;
2. Series Code : TPF-One way adjustable balancing valve, STPF-Two ways adjustable balancing valve;
3. The connection form: LM-Threaded connection, BM-Plate connection+Threaded connection;
4. Rated flow:40-40L/min, 60-60L/min, 80-80L/min, 100-100L/min;
5. Rated pressure:25-25MPa, 35-35MPa;
6. Cracking Ratio:4.2-4.2:1, 4.5-4.5:1, 5.2-5.2:1, 8.2-8.2:1, 10-10:1;

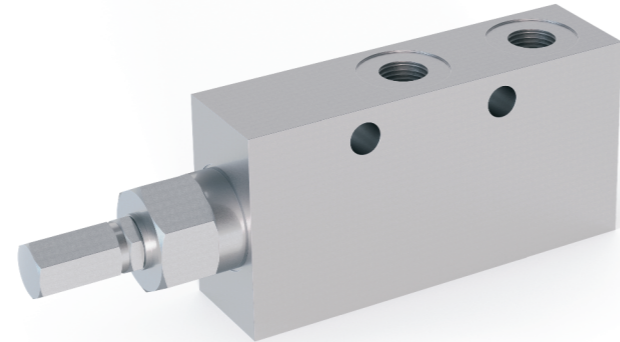

技术参数 Technical Specifications

公称流量：60 L/min	Nominal Flow : 60 L/min
公称压力：32 MPa	Nominal Pressure : 32 MPa
控制压力：2-4.5 MPa	Control Pressure : 2-4.5 MPa
开启比：4.2:1	Cracking Ratio : 4.2:1

图形符号 Hydraulic Schematic

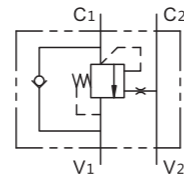

外形尺寸 Overall Dimension

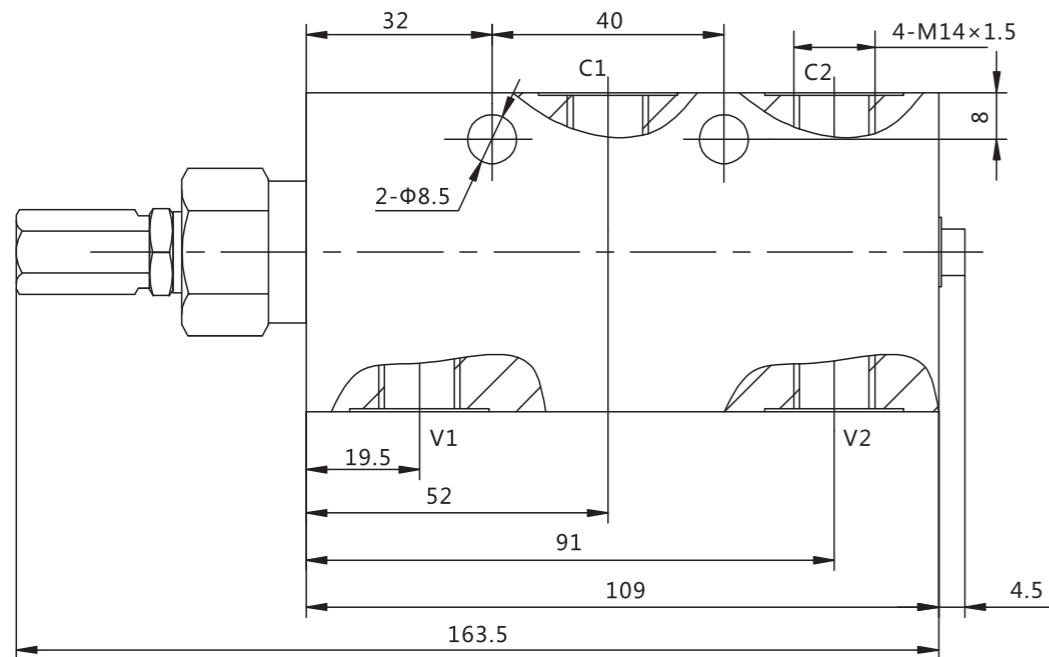

BLV-STPFLM-80-35-4.2 (BLV-DBFD10/35-L-B) 型平衡阀 BLV-STPFLM-80-35-4.2 (BLV-DBFD10/35-L-B) Type Counterbalance Valve

技术参数 Technical Specifications

公称流量：60L/min
公称压力：35MPa
控制压力：2-4.5MPa
开启比：4.2:1

Nominal Flow : 60L/min
Nominal Pressure : 35MPa
Control Pressure : 2-4.5MPa
Cracking Ratio : 4.2:1



图形符号 Hydraulic Schematic

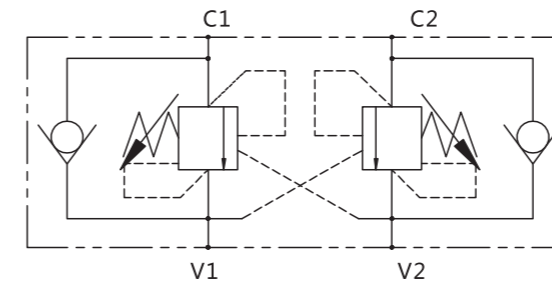

外形尺寸 Overall Dimension

